

MiniMax™ IR Series

Rugged miniature DPSS laser in a rectangular device package with integrated thermoelectric cooler, temperature sensor, and power monitor allowing stable operation over a broad ambient temperature range.



Features:

- **Small-size case-neutral rectangular package**
- **Alignment-free optical design**
- **High polarization ratio**
- **Long-term power stability**

Optical Specifications	MiniMax™ IR350
Operating Mode and Wavelength	Continuous Wave, 1064 +/- 1 nm
TEM ₀₀ Output Power	>350 mW
Power Stability (2 hour with +/- 2 °C Ambient Temperature Change)	< 2%
RMS Noise	< 2%
Beam Diam. at Output Window and Full-Angle Divergence (1/e ² , typ.)	200 μm and 10 mrad
Mode Quality (typ., M ²)	1.5
Beam Roundness	< 1.1:1
Bore Sighting and Offset Accuracy	< 10 mrad and < 1 mm
Polarization Ratio	> 200:1

Electrical Input Requirements ¹	Laser	TEC
Voltage	< 2.5 V	<7.2 V
Current	< 1.4 A	< 2.0 A
Electrical Power	< 3.1 Watt	< 14.4 Watt
Photodiode Current	800 < I(pd) < 1600 μA	
Temperature Sensor	10 kΩ, 100 μA	

Other Specifications	
CDRH Class	IIIb
Warm-up Time	< 1 minute
Storage Temperature	-40 to +80 °C
Operating Temperature at Laser Base	+10°C to +40°C (non-condensing)

Specifications subject to change without notice.

Other notes:

1. SCL offers breakout 1x1 breakout board adapter

Mechanical Specifications

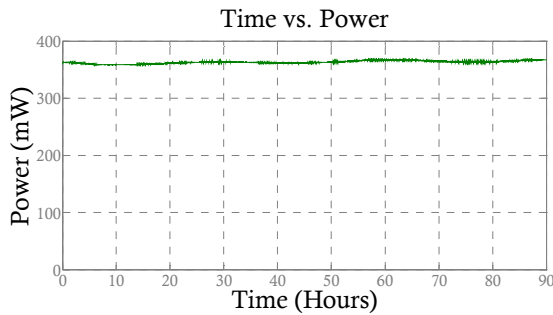
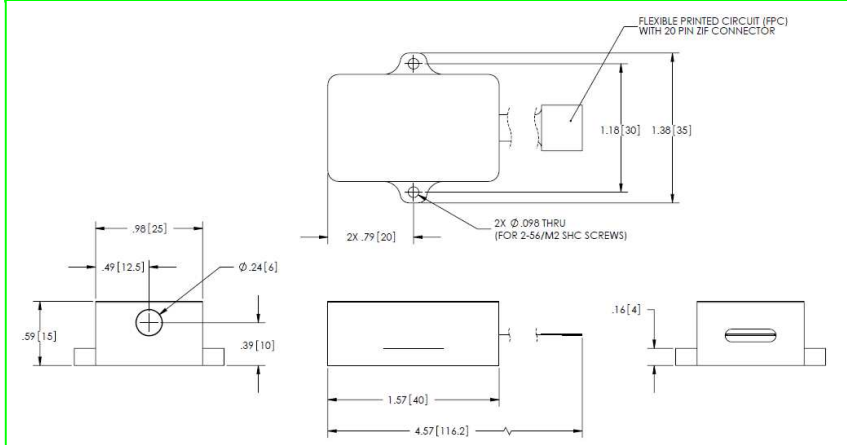

Notes

Snake Creek Lasers offers a limited warranty.

The MiniMax™ Series is an electronic device, and, as such, subject to damages due to electro-static discharge, overpowering, and transients.

Thermal management of the MiniMax™ Laser must be included in the OEM design. Failures due to inadequate thermal management will void the warranty.

Please refer to Snake Creek Lasers' Warranty Statement / Return Policy for details. For assistance in any integration issues, please contact our experienced Applications Team at sales@snakecreeklasers.com

U.S. and international patents pending.

Class IIIB <500 mW



This product is sold as an OEM laser product and does not fully comply with 21 CFR 1020 and IEC 60825-1 : 1993 as applicable.



61 Railroad Ave.
 Hallstead, PA 18822
 Tel.: 570-879-4992
 Fax: 570-879-0912
www.snakecreeklasers.com